



sakumetall

17.00.31 version 01

INSTALLATION MANUAL FOR FIRE PROTECTION PROFILE PRODUCT PRESTO E30



TABLE OF CONTENT

1	PRODUCT TYPES.....	2
2	INSTALLATION	2
2.1	Fixtures	2
2.2	Sequence of door installation activities	2
2.3	Sequence of wall installation activities.....	4
2.4	Glazing	4

1 PRODUCT TYPES

This installation manual covers only following product types:

Steel profile fire protection products:

1. PFD111 – steel profile fire door of Forster Presto profile, Estonia E30;
2. PFC111 – steel profile fire door/wall of Forster Presto profile, Estonia E30;
3. PFW111 – steel profile fire window/wall of Forster Presto profile, Estonia E30.

2 INSTALLATION

2.1 Fixtures

Materials used for installation shall be non-flammable. For fixing of door jamb and window frame use steel bars \varnothing 10mm and alternatively also various fixing anchors \varnothing 8 \times 120/50 and \varnothing 8 \times 70/50. Drills suitable for relevant wall type will be used for drilling. The size of plastic cover caps of fixing apertures of jamb is 19 mm. Upon fixing of jamb between steel profiles, in support profiles of light walls made of gypsum and mineral wool jamb can also be fixed with self-threading screws, with minimum diameter 6mm. Length of screw shall be chosen so that it would penetrate steel profile at least 10mm. Fixing methods are shown on figure 1. For packing material of construction aperture and jamb use rock wool with density 70 kg/m³.

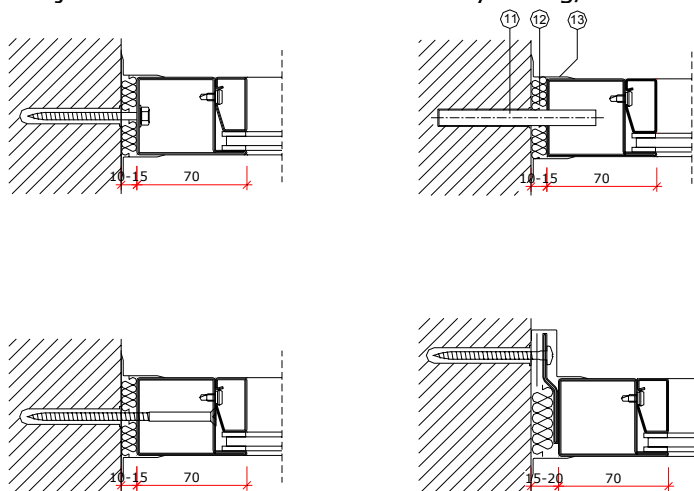

Figure 1

2.2 Sequence of door installation activities

1. Check suitability of the existing construction aperture. The largest allowed dimensions of construction aperture are: jamb width +30mm and height +30mm. In case of larger gaps bring the construction aperture into conformity with necessary dimensions.
2. Check availability of fixtures and tools.



- Place jamb without door sheet in construction aperture. Check horizontal position of door threshold with water-level. If necessary, support the threshold at the edges of jamb and in the centre, in order to avoid excessive bending of threshold upon stepping.
- Level the hinge side of jamb and drill through the jamb fixing aperture for upper dowel no.1 (Figure 2) at minimum to the depth of 80 mm (in case of bar). Fix dowel in the aperture through the jamb, fixing the dowel beforehand with screw end. Then, using the chuck key, turn the screw into such depth that gap between construction aperture and jamb would be equal on both sides. Then prepare a block of non-flammable material (e.g. gypsum, steel) with thickness 10 mm, width 45 mm and length maximum 100 mm and place it between jamb and wall against fixing screw. Then tighten the screw. Do the same with lower aperture of the hinge side 2 and opposite fixing apertures 3 and 4. Check vertical position of lateral surfaces of jamb with level.

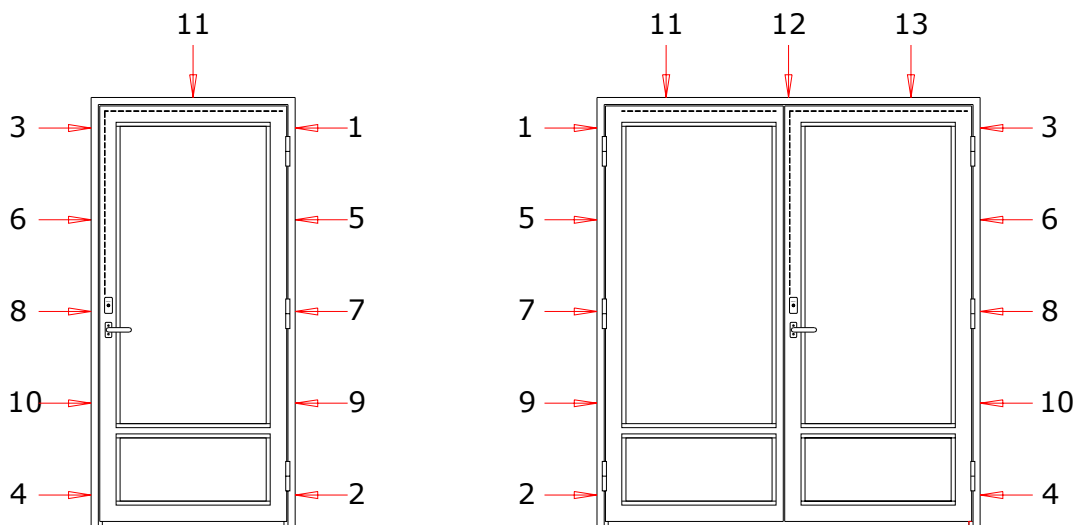

Figure 2

- Lift door sheet on hinges and check parallelism of door sheet and jamb slots as well as external door surface and jamb surfaces. If necessary, adjust with screws and correct thickness of support blocks.
- Drill all remaining fixing apertures and fix the screws, dowels and support blocks and tighten the screws. Support blocks shall be installed beside all fixing screws.
- Jamb can be fixed also with steel anchors with bar diameter 10 mm, fixing the jamb with welding to the anchor. Welding can be performed only by qualified welder.
- Close the fixing apertures with plastic caps.
- Seal the gap in the wall between construction aperture and jamb.
NB! In case of fire door the recommended sealing material shall be rock wool with density at least 70 kg/m³.
- Sealed gaps shall be finished on the top with construction plates, plastered or covered with metal slat fixed with tensile rivets.
- Upon installation of door seal ensure that protruding lip of the seal is facing the profile.
- Locks (and other hardware) shall be installed according to installation manuals of hardware. Fix handles and hub to the lock and check closure and operation of door wind bolt (and other lock bolts) by opening and closing the door. Check opening of lock with keys.
NB! Ensure that all hardware are suitable for use with product of this fire safety class.
- Check with induction tester that the product is not under live voltage. Otherwise switch off the power and ground the product. Electrical operations can be performed only by qualified electrician. Saku Metall AS does not perform electrical operations.



2.3 Sequence of wall installation activities

1. Check suitability of the existing construction aperture. The largest allowed dimensions of construction aperture are: wall frame width +30mm and height +25mm. In case of larger gaps bring the construction aperture into conformity with necessary dimensions.
2. Place the frame without glass in construction aperture, and then check horizontal and vertical position of wall frame with water-level, support frame ends, if necessary.
3. Level the right side of frame and drill through the wall fixing aperture for upper dowel no.1 (Figure 23) at minimum to the depth of 80 mm (in case of bar). Fix dowel in the aperture through the jamb hole, fixing the dowel beforehand with screw end. Then, using the chuck key, turn the screw into such depth that gap between construction aperture and jamb would be equal on both sides. In case of bar knock the steel bar in the aperture. Then prepare a block of non-flammable material (e.g. gypsum, steel) with thickness 10 mm, width 45 mm and length maximum 100 mm and place it between jamb and wall against fixing screw. Then tighten the screw. Do the same with lower aperture of the right side (2) and upper left fixing apertures (3) and (4). Check vertical position of lateral surfaces of wall with level.
4. Drill all remaining fixing apertures and fix the screws, dowels and support blocks and tighten the screws. Support blocks shall be installed beside all fixing screws.
5. Jamb can be fixed also with steel anchors with bar diameter 10 mm, fixing the jamb with welding to the anchor. Welding can be performed only by qualified welder.
6. Now install the glass. See point 2.4 Glazing.
7. Seal the gap in the wall between construction aperture and jamb.
NB! In case of fire door the recommended sealing material shall be rock wool with density at least 70 kg/m³.
8. Sealed gaps shall be finished on the top with construction plates, plastered or covered with metal slat fixed with tensile rivets.

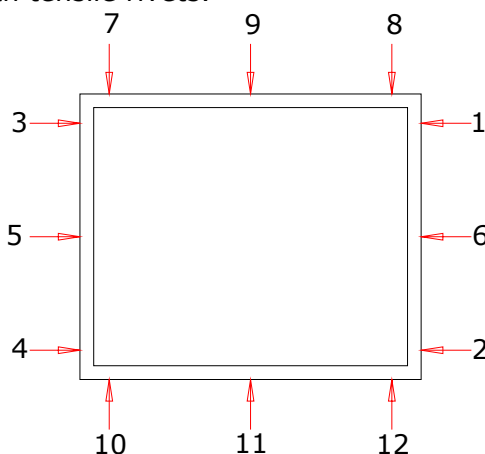

Figure 3

2.4 Glazing

Glazing of fire doors will take place in AS Saku Metall, but in case of wall and window glazing will be performed immediately on the site. 7 types of glass are used for products with E30 fire protection class (see Figure 4). As an alternative, glass can be replaced with ordinary gypsum plate with thickness 13 mm, surrounded with 1,25 mm steel sheets (e.g. Gyproc GN). Upon glazing use special ceramic fireproof seals (Keraband) or as an alternative Forster rubber glass seals. Window/wall frame is pre-supplied with glazing screws Forster 906.578.

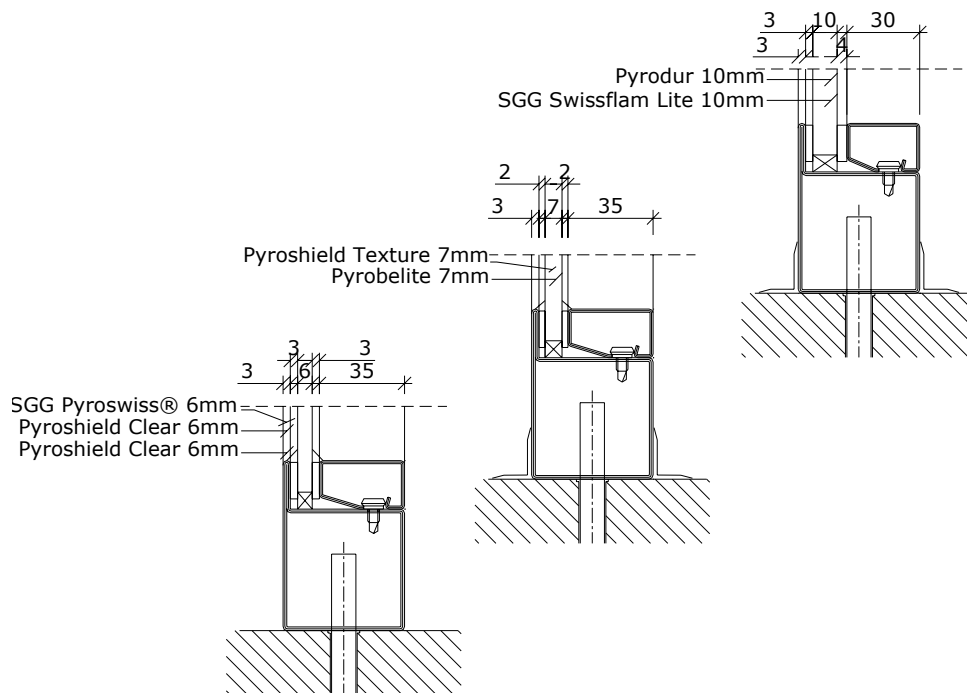

Figure 4

Sequence of glass installation operations.

1. Glazing aperture of frame shall be cleaned of dust and dirt.
2. Seal with correct thickness corresponding to the glass shall be stuck on the glazing lug of the frame (see Figure 5).
3. In the corners under the glazing aperture (approximately 50-100mm from the edge) glazing blocks (4) shall be installed (see Figure 5) so that their height would be 10 mm and the thickness would be equal to the thickness of glass.
NB! Glazing blocks shall be made of non-flammable material. Suitable blocks are e.g. Flammi12.

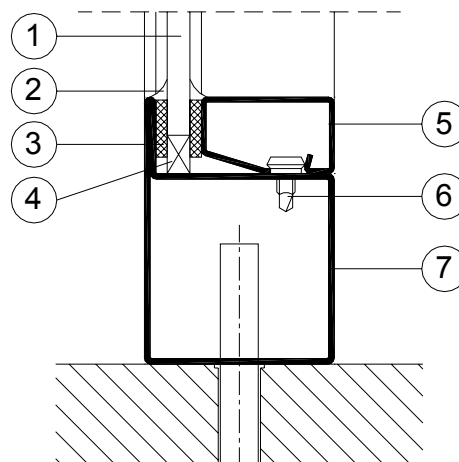

Figure 5

4. Then lift the glass into the aperture on glazing blocks so that equal gaps would remain on both sides between glass and frame (maximum 8 mm) and maximum 6mm at the top.



5. Stick the seal with correct thickness on glazing slat and fix the glass with glazing slat first at the top, then at the bottom and sides. For fixing of slat use rubber or plastic hammer.
6. Seal surfaces shall be finished on both sides with fire silicon (2) in order to protect glass from moisture and dirt (optional).