









## Installation manual for fire-resistant steel doors FQ(L) EI30, EI60 and EI120



### Attention! General warnings!

A Series of precautions must be taken to install this door. For safety reasons pay attention to following warnings and instructions! In case of doubt contact the supplier. This manual is meant for experienced installer.

-  This manual includes only the installation of door. Additional elements require separate instructions.
-  Read this manual carefully before installation.
-  Certain parts of this product may have sharp edges. Protective gloves are recommended.
-  Parts of the door are heavy.
-  All that is necessary to install this door is included in the package except insulation material between the wall and the frame and support blocks. Adding other elements may affect safety and warranty.
-  Make sure that there is enough light in the installation area. Remove items not necessary and dirt. Unauthorized persons (especially children!) may get hurt if present.
-  Make sure that the wall is strong enough for installation. In case of doubt contact the constructor.

In case of questions contact AS Saku Metall Uksetehas.



## 1 TOOLS AND FIXINGS

1. When installing the door frame into concrete or masonry walls (figure 1 and 2), the use of  $\varnothing 10$  mm steel rods or  $\varnothing 8$  mm screws and  $\varnothing 10$  mm dowels is required. The use of thicker screws is allowed, in such case the use of dowels is not required. Length of steel rods and screws must be 100 mm or more. Dimension of hexagon head of fixing screw is 13 mm. For drilling in masonry and concrete walls use masonry drill with diameter in accordance to the screw size. Self-tapping screws sized  $\varnothing 6$  mm and higher are allowed when installing the door frame into steel profile (figure 3) and gypsum walls (figure 4). In such case, the screw must penetrate the steel profile by minimum of 10 mm.
2. For frames with ESSVE sleeves use the following fixings with Torx 30 head (figure 5):
  - Concrete walls: ESSVE art. 105287 (7,5x92), drill hole  $\varnothing 6 \times 100$  mm
  - Lightweight masonry walls: ESSVE art. 105232 (8,0x120), no pre-drilling required
  - Wooden walls: ESSVE art. 105294 (6,0x65), no pre-drilling required
  - Steel walls: ESSVE art. 105379 (7,0x45), no pre-drilling requiredUse 10 mm hex key to adjust the sleeves.
3. Socket wrench with a maximum diameter of  $\varnothing 18,5$  mm can be used.
4. Covering caps for fixings are with a diameter of  $\varnothing 19$  mm.
5. Support blocks used for levelling the frame must be fire-resistant materials.

## 2 DIFFERENT METHODS OF INSTALLATION

1. Fire resistance class EI30 doors may be installed into concrete, masonry or stone walls with the minimum density of  $450 \text{ kg/m}^3$  and to flexible constructions.
2. Fire resistance class EI60 doors may be installed into concrete, masonry or stone walls with the minimum density of  $450 \text{ kg/m}^3$ .
3. Fire resistance class EI120 doors may be installed into concrete, masonry or stone walls with the minimum density of  $450 \text{ kg/m}^3$ .

Figure 1.

Frame installation with  $\varnothing 8$  and L-100 screws

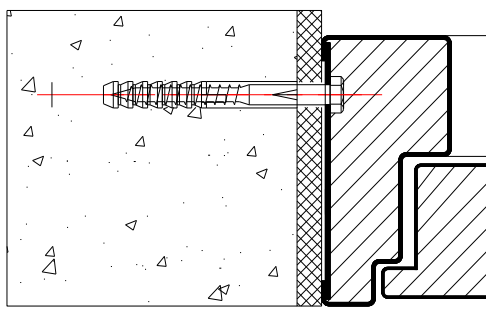

Figure 2.

Frame installation with  $\varnothing 10$  steel rod

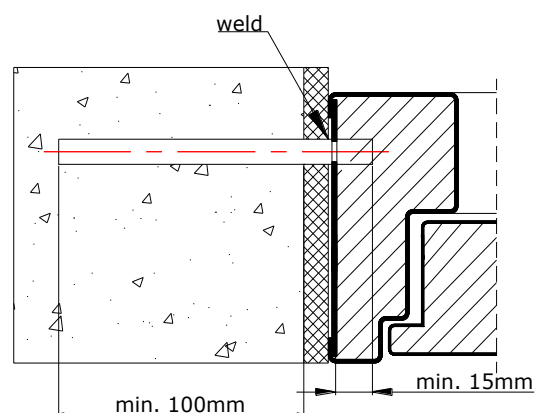
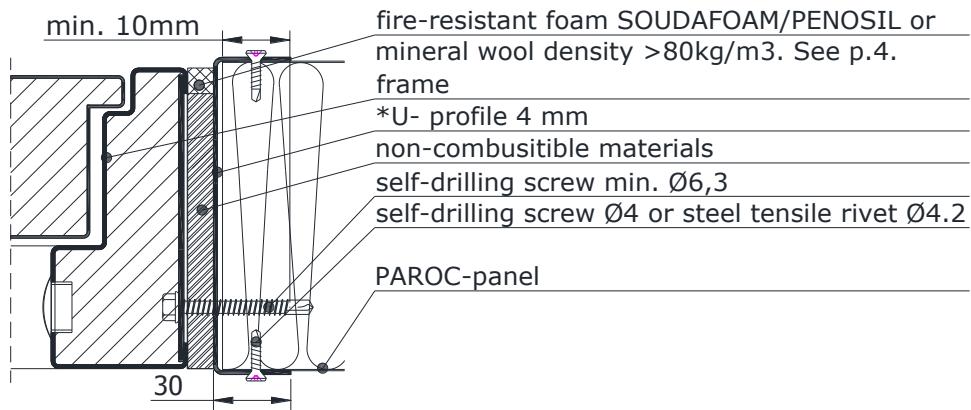

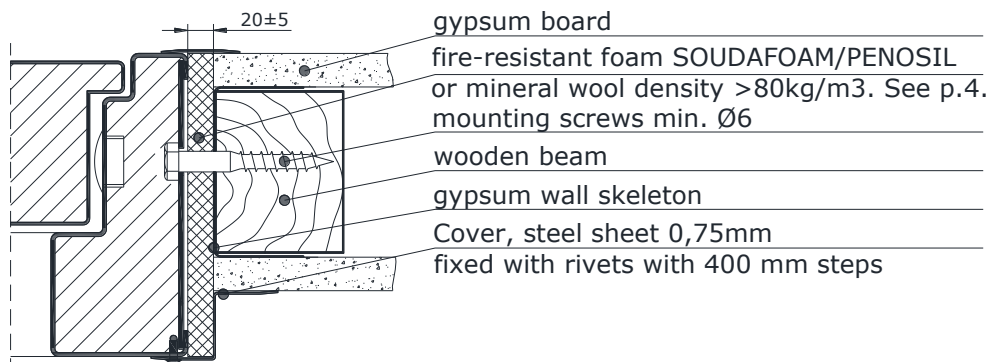

Figure 3. Fixing of the frame in steel profile



\*U- profile: 4 mm steel, covered with fire resistant coating. Profile must cover the whole perimeter of the installation cavity.

Figure 4. Fixing of the frame in gypsum wall



Ver.1

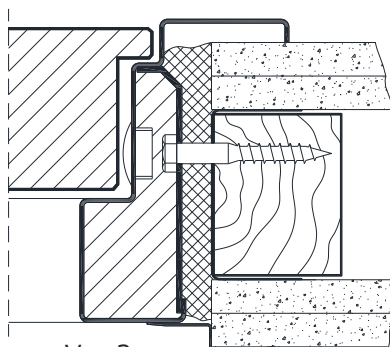

Ver.2

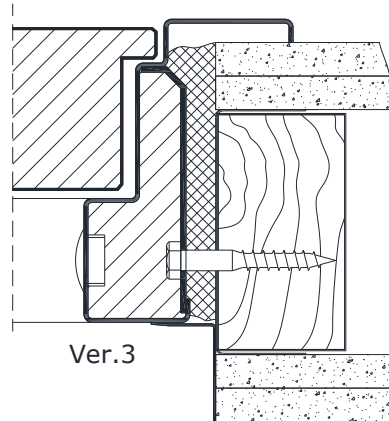

Ver.3



Figure 5.

Fixing of the frame in hollow masonry wall

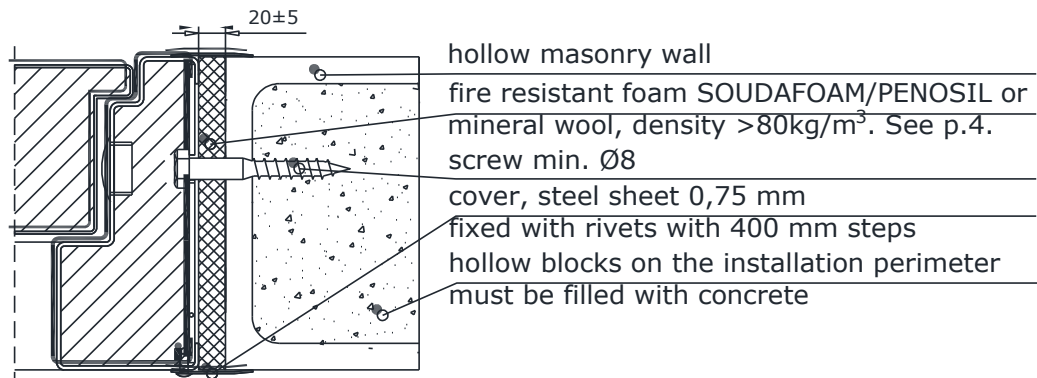
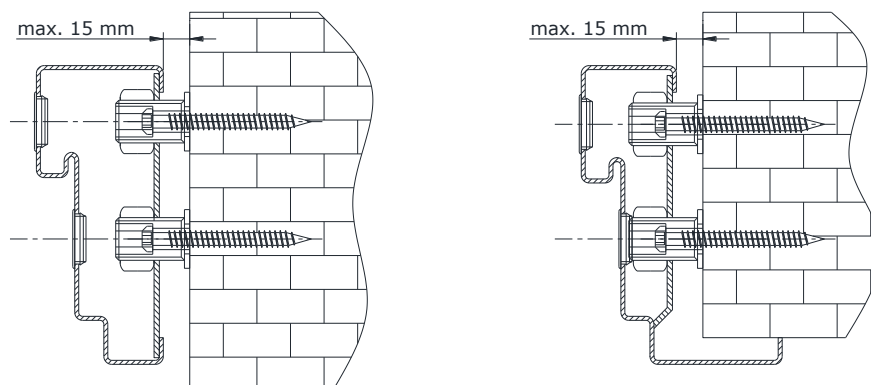

Figure 6.

Fixing of the frame with sleeves



### 3 ORDER OF INSTALLATION

1. Upon placing the door on the ground use a sheet of rubber, cardboard, wood or plastic for protection of the paint layer.
2. Check the presence of fixings and tools.
3. Check the preparation of construction aperture. The greatest allowed width of construction aperture from frame is +40 mm and height +20 mm (for frames with sleeves +30 mm and +15 mm accordingly). In case of larger gaps bring the construction aperture into compliance with the required dimensions. Ensure that frame and fixing devices do not contact possible public utility networks inside the wall.
4. Frames of external doors which are assembled on site are to be siliconized at the tenon of threshold. Tenon which is on the external side from door seal is to be siliconized. Allowed silicones are Soudal Soudaflex 40FC, Soudal Silirub 2/S and Penosil General Silicone.
5. Place the frame without the door into the construction aperture, at specified distance from external surface of the wall. Ensure that the frame is supported at the bottom to prevent deformation of the frame during operation. Check levelling of upper profile of the frame. Support the threshold as close as possible to the place of fixture, to avoid its excessive bending upon stepping. Use metal plates as bearing support blocks.



6. Level the hinge side of the frame and start fixing the frame from fixing apertures 1, 2 and 3 (figure 7.).
  - 6.1. On a frame without sleeves, when tightening the screws ensure that gaps between the frame and wall are equal. Place support blocks in the gap against screw, in order to support every fixing point of the frame and then tighten the screws. Check vertical position of side surfaces of the frame. If necessary, loosen the screw and correct position of the frame.
  - 6.2. On frames with sleeves, tighten the sleeves against the wall (figure 6). Frames with sleeves do not require support blocks between the frame and the wall. If the sleeve does not extend to the wall, use additional fire-resistant plates. Use proper fixings for ESSVE sleeves (section 1 Tools and fixings). Tighten the screws.
7. Ensure that there is lubricant on hinges and support bearings.
8. Lift the door leaf on the hinges. Check parallelity of the gaps between the door leaf and the frame, and hinge-side door surface and the frame surface. If necessary adjust the screws and width of the support blocks. On frames with sleeves loosen the screw and correct the gaps by adjusting the sleeves with a hex key.
9. Fix the frame in all of the other remaining fixing points, ensuring parallelity of gaps and support of fixing points with support blocks (or sleeves).
10. Upon partial fixing of the frame with steel bar ensure minimum projection of bar from fixing flap of the frame (figure 2). Additional fixing of the frame with welding joint is allowed.
11. Check with induction tester that the product is not under live electric voltage. Otherwise switch off the power and perform grounding of the product. Electrical work may be performed only by a qualified electrician.
12. Close fixing apertures of the frame with plastic caps.
13. Siliconize the gaps between the floor and frame of external doors. External and internal side must be sealed. External gaps between the door frame and wall must be sealed with silicone on frames with wall covering slats (type YM). Allowed silicones are Soudal Soudaflex 40FC, Soudal Silirub 2/S and Penosil General Silicone.



Figure 7.  
Fixing points of the frame

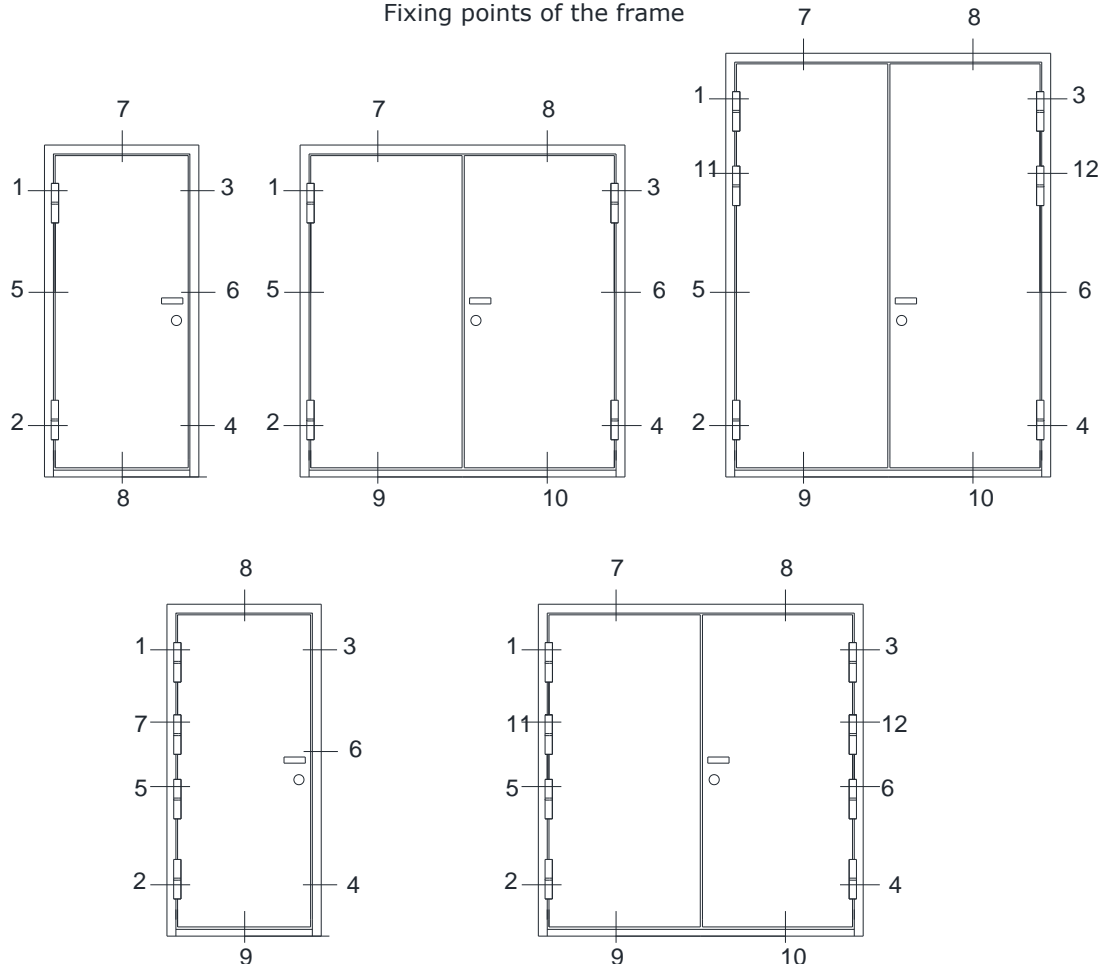

#### 4 FILLING THE GAP BETWEEN THE FRAME AND THE WALL. FINISHING.

1. Fire resistance classes EI30 and EI60 - fill the gaps between the frame and the wall with fire resistant foam Soudafoam FR or Penosil Premium FireRated Gunfoam or mineral wool with density >80kg/m<sup>3</sup>.
2. Fire resistance class EI120 - fill the gaps between the frame and the wall with mineral wool with density >80kg/m<sup>3</sup>.
3. After the installation of foam or mineral wool, check for tightening of external gaps of the frame check free movement of door.
4. Filled gaps shall be finished with construction plate, plaster mixture or covered with metal slat fixed with rivets.

NB! Door package does not include infilling and support block materials!

#### 5 HARDWARE INSTALLATION

1. Install locks according to the installation manual. It is forbidden to remove the blocks of mineral wool located at the sides of the lock openings! Use self-drilling screws for



fastening the lock. Fix handles to the lock and check closure and operation of the lock tumbler (and latch bolt) with opening and closing of door. Check opening of lock with keys.