









Installation manual for metal doors



Attention! General warnings!

A Series of precautions must be taken to install this door. For safety reasons pay attention to following warnings and instructions! In case of doubt contact the supplier. This manual is meant for experienced installer.

-  This manual includes only the installation of door. Additional elements require separate instructions.
-  Read this manual carefully before installation.
-  Certain parts of this product may have sharp edges. Protective gloves are recommended.
-  Parts of the door are heavy.
-  All that is necessary to install this door is included in the package except insulation material between the wall and the frame and support blocks. Adding other elements may affect safety and warranty.
-  Make sure that there is enough light in the installation area. Remove items not necessary and dirt. Unauthorized persons (especially children!) may get hurt if present.
-  Make sure that the wall is strong enough for installation. In case of doubt contact the constructor.

In case of questions contact AS Saku Metall Uksetehas.



1 TOOLS AND FIXINGS

1. Use Ø8x100 screws and Ø10 mm dowels to install the frame. Dimension of hexagon head of fixing screw is 13 mm. For drilling in stone and concrete walls use stone drill with Ø10 mm diameter.
2. For frames with ESSVE sleeves use the following fixings with Torx 30 head:
 - Concrete walls: ESSVE art. 105267 (7,5x65), drill hole Ø6x100 mm
 - Lightweight concrete walls: ESSVE art. 105232 (8,0x120), no drilling required
 - Wooden wall: ESSVE art. 105294 (6,0x65), no drilling required
 - Steel walls: ESSVE art. 105379 (7,0x45), no drilling requiredUse 10 mm hex key to adjust the sleeves.
3. Socket wrench with a maximum diameter of Ø18,5 mm can be used.
4. Covering caps for fixings are with a diameter of Ø19 mm.

2 ORDER OF INSTALLATION

1. Upon placing the door on floor or ground use rubber, board, wood or plastic material for protection of paint layer.
2. Check the presence of fixings and tools.
3. Check the preparation of construction aperture. The greatest allowed width of construction aperture from frame is +40 mm and height +20 mm (for frames with sleeves +30 mm and +15 mm accordingly). In case of larger gaps make the construction aperture into compliance with the required dimensions. Ensure that frame and fixing devices do not contact possible public utility networks inside the wall.
4. To assemble frames on site, connect frame parts and fasten with correct fasteners (figure 8). Thresholds are fastened with screws or spring pins (figure 8, view B), except 5mm sheet thresholds, which are fastened with flat head bolts M5x10 (figure 8, view C). Spring pins are used when threshold tab height from floor is lower than 10mm, otherwise screws are used. Frames of external doors which are assembled on site are to be siliconized at the tenon of threshold. Tenon which is on the external side from door seal is to be siliconized. Allowed silicones are Soudal Soudaflex 40FC, Soudal Silirub 2/S and Penosil General Silicone.
5. Place the frame without door sheet in construction aperture, at specified distance from external surface of wall. Ensure that support points of the frame remain under side profiles, to prevent later sinking of door. Check levelling of upper profile of the frame. Support the threshold as close as possible to the place of fixture, to avoid its excessive bending upon stepping. Use metal plates as bearing support blocks.
6. Level the hinge side of the frame and start fixing the frame from fixing apertures 1, 2 and 3 (figure 7.).
 - 6.1. On a frame without sleeves, when tightening the screws ensure that gaps between the frame and wall are equal. Place support blocks in the gap against screw, in order to support every fixing point of the frame and then tighten the screws finally. Check vertical position of side surfaces of the frame. If necessary, loosen the screw and correct position of the frame.
 - 6.2. On frames with sleeves, tighten the sleeves against the wall (figure 6.). Frames with sleeves do not require support blocks between the frame and the wall. If the sleeve does not extend to the wall, use additional plates. Use proper fixings for ESSVE sleeves (section 1 Tools and fixings). Tighten the screws.
7. Ensure that there is lubricant on hinges and support bearings.
8. Lift the door sheet on hinges. Check parallelity of gaps between door sheet and frame and external door surface and the frame surface. If necessary adjust the screws and width of the support blocks. On frames with sleeves loosen the screw and correct the gaps by adjusting the sleeves with a hex key.



9. Fix the frame in all of the other remaining fixing points, ensuring parallelity of gaps and support of fixing points with support blocks.
10. Upon partial fixing of the frame with steel bar ensure minimum projection of bar from fixing flap of the frame (figure 2). Additional fixing of the frame with welding joint is allowed.
11. Check with induction tester that the product is not under live electric voltage. Otherwise switch off the power and perform grounding of the product. Electrical work may be performed only by qualified electrician.
12. Close fixing apertures of the frame with plastic caps.
13. Siliconize the gaps between the floor and threshold of external doors. External and internal side must be sealed. External gaps between the door frame and wall must be sealed with silicone on frames with wall covering slats (type YM). Allowed silicones are Soudal Soudaflex 40FC, Soudal Silirub 2/S and Penosil General Silicone.

3 DIFFERENT METHODS OF INSTALLATION

Figure 1.

Frame installation with Ø8 and L-100 screws

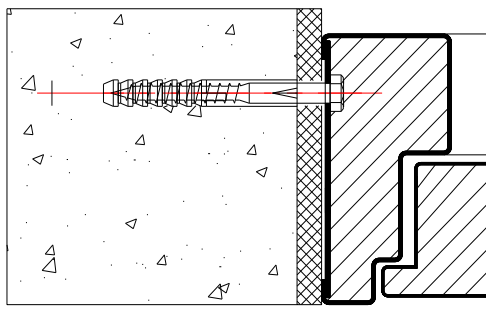

Figure 2.

Frame installation with Ø10 steel rod

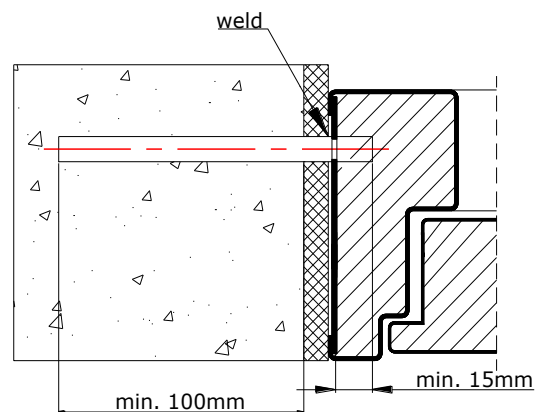
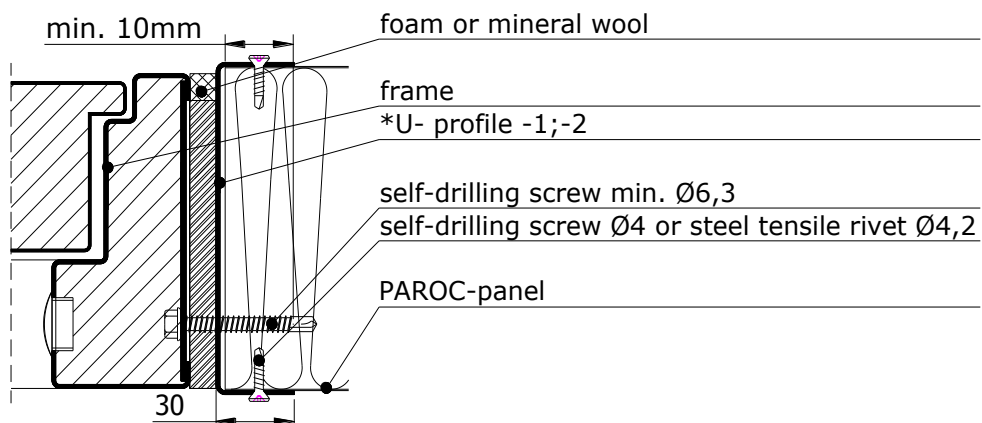

Figure 3.

Fixing of the frame in steel profile



*U- profile -1: ZE steel sheet 1,5mm L-300, frame height <2320
 -2: ZE steel sheet 3,0mm L-300, frame height >2320



Figure 4.
Fixing of the frame in gypsum wall

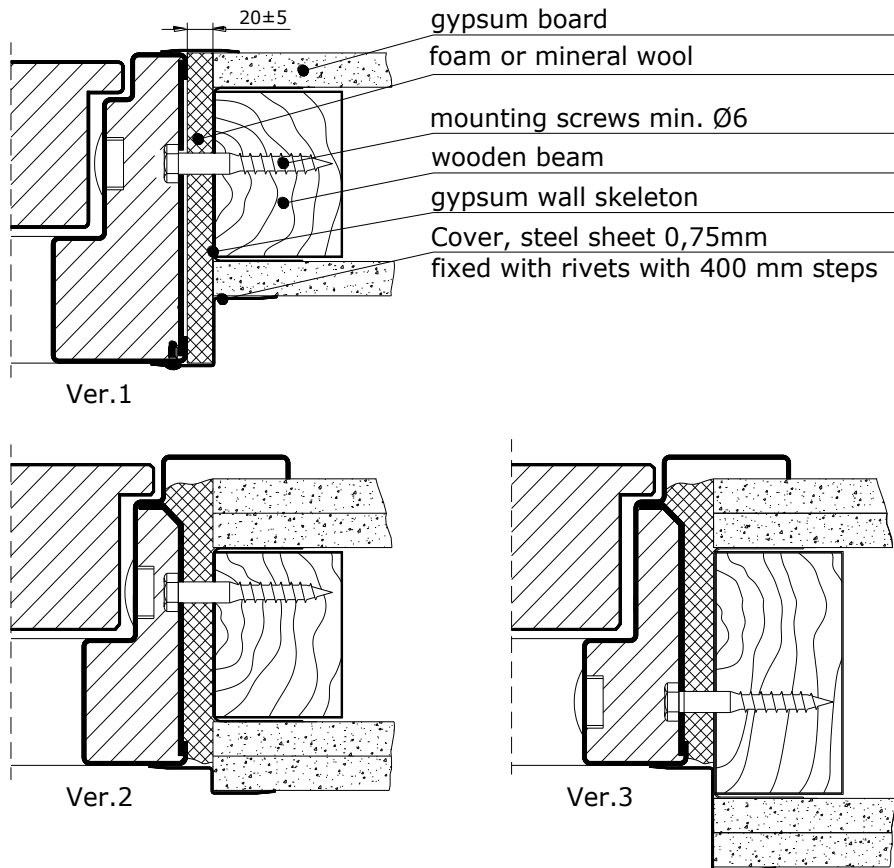

Figure 5.
Fixing of the frame in thermal profile

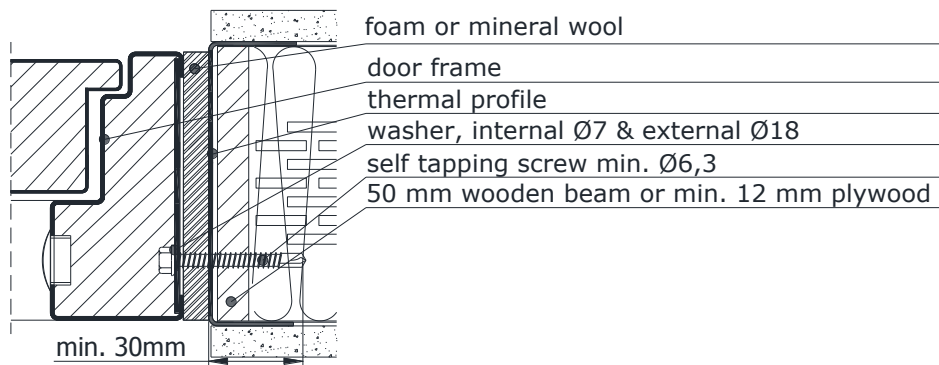



Figure 6.
Frame installation with sleeves

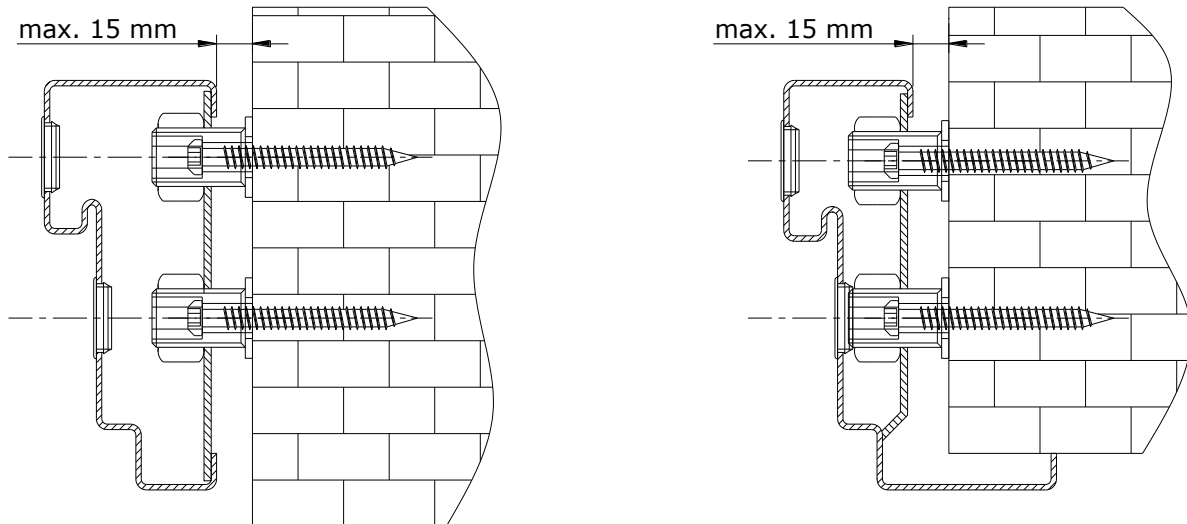

Figure 7.
Fixing points of the frame

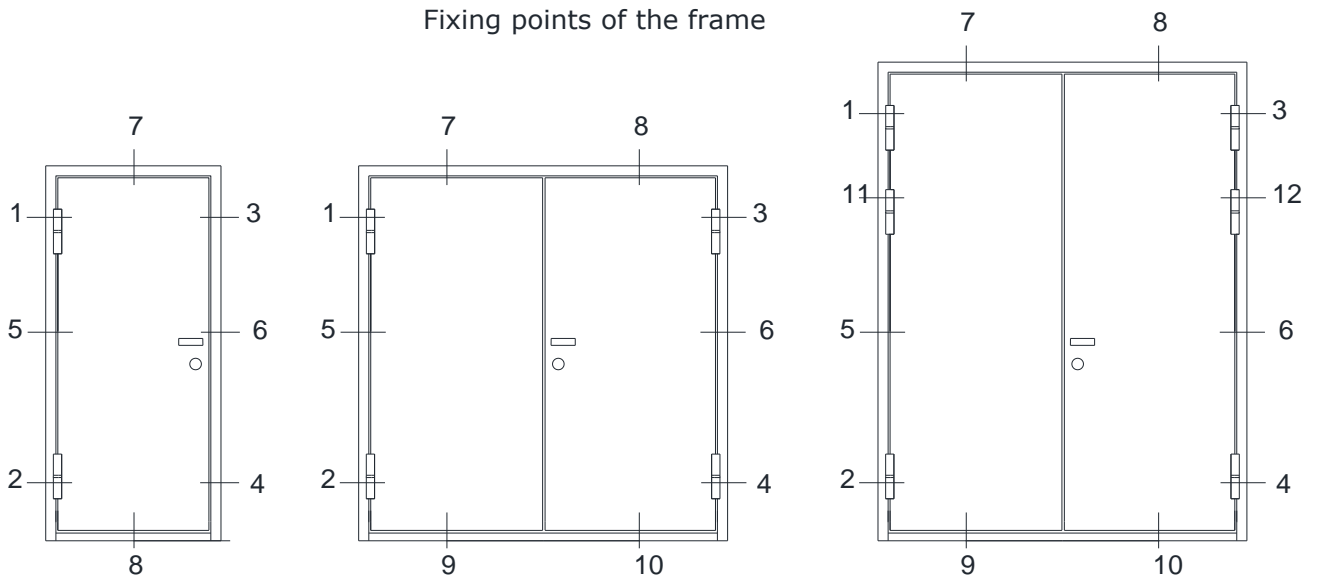
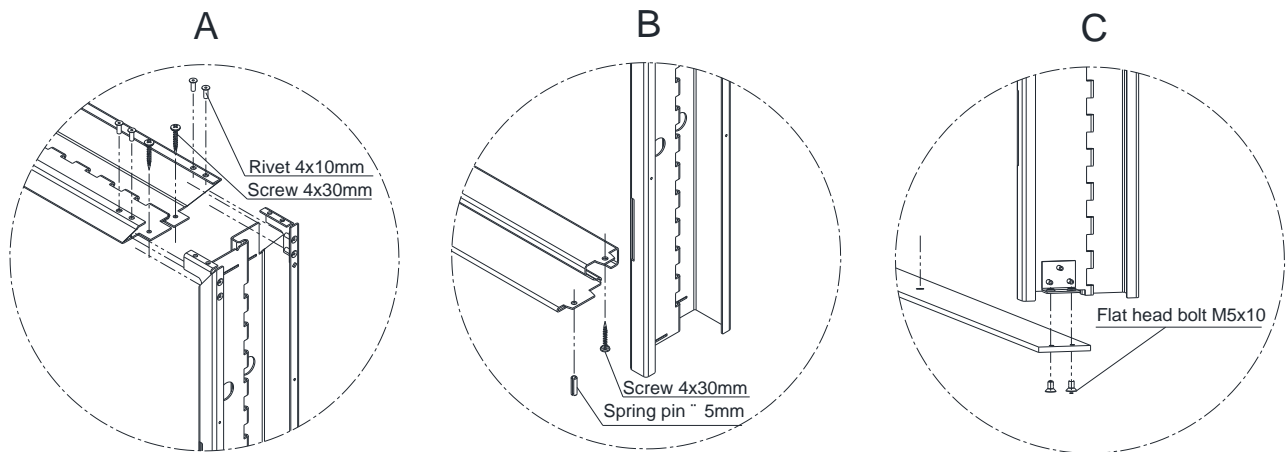

Figure 8.
Assembling frame on site



4 FILLING THE GAP BETWEEN THE FRAME AND THE WALL. FINISHING.

1. Fill side gaps between the frame and the wall with foam or mineral wool.
2. After tightening of external gaps of the frame check free movement of door.
3. Filled gaps shall be finished with construction plate, plaster mixture or cover with metal slat fixed with rivets.

NB! Door package does not include infilling and support block materials!

5 HARDWARE INSTALLATION

Install locks according to installation manuals of locks. It is forbidden to remove the blocks of mineral wool located at the sides of the lock openings! Use self-drilling screws for fastening the lock. Fix handles to the lock and check closure and operation of lock tumbler (and latch bolt) with opening and closing of door. Check opening of lock with keys.