









Installation manual for profile product Forster Presto XS



Attention! General warnings!

A Series of precautions must be taken to install this product. For safety reasons pay attention to following warnings and instructions! In case of doubt contact the supplier. This manual is meant for experienced installer.

-  Read this manual carefully before installation.
-  Protective gloves are recommended.
-  Parts of the product are heavy.
-  All that is necessary to install this product is included in the package except insulation material between the wall and the frame and support blocks. Adding other elements may affect safety and warranty.
-  Make sure that there is enough light in the installation area. Remove items not necessary and dirt. Unauthorized persons (especially children!) may get hurt if present.
-  Make sure that the wall is strong enough for installation. In case of doubt contact the constructor.

In case of questions contact AS Saku Metall Uksetehas.



TABLE OF CONTENT

1	PRODUCT TYPES	2
2	INSTALLATION	2
2.1	Fixtures	2
2.2	Order of installation for door.....	3
2.3	Order of installation for window/wall.....	5
2.4	Glazing	5

1 PRODUCT TYPES

This installation manual covers only following steel profile products:

1. Internal steel profile Forster Presto XS products.

2 INSTALLATION

2.1 Fixtures

Typical fastener variants according to the wall types are shown in Table 1. When fixing into concrete, concrete masonry, brick, lightweight concrete, or wood, select the length of the screw so that the screw thread reaches at least 50 mm into the wall.

When installing the product between steel construction of light walls made of gypsum or stone wool, the frame may be also fixed with self-tapping screws, with a minimum diameter of 6 mm. The length of the screws must be selected so that its thread passes through the steel profile by at least 10 mm. For sealing material between construction aperture and profile frame use fixing foam or stone wool. Typical fastening methods are shown in figure 1.

Table 1 Typical fasteners variants according to wall types

Wall type	Fastener variants
Concrete, concrete masonry or brick	Concrete screw $\varnothing 7.5 \times 92$ (e.g. Essve 105287) Screw $\varnothing 8 \times 100$ (e.g. Würth W-1192-8-100) + plastic wall plug
Lightweight concrete	Concrete screw $\varnothing 10,5 \times 110$ (näiteks THDEX 10110)
Steel	Self-tapping screw $\varnothing 7 \times 45$ TX30 (e.g. Essve 105379)
Wood	Wood screw $\varnothing 6 \times 65$ TX30 (e.g. Essve 105294)



1	Fixing foam or stone wool
2	Cover steel sheet 0,7 mm
3	Screw
4	Screw + wall plug
5	Wood screw
6	Self-tapping screw

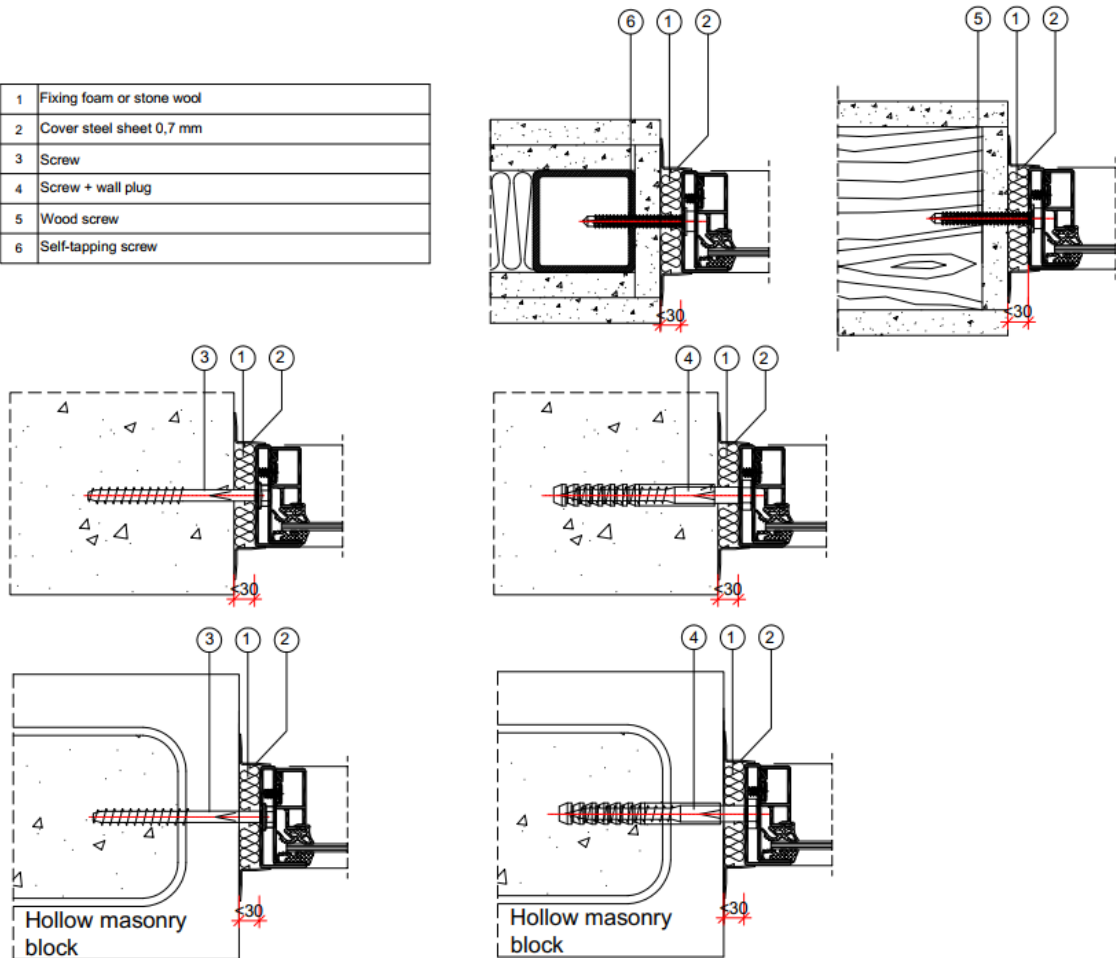

The cavities at the edges must be filled with concrete!

The cavities at the edges must be filled with concrete!

Figure 1 Typical fastening methods

2.2 Order of installation for door

1. Check the preparation of construction aperture. The greatest allowed width of construction aperture from frame is +60 mm and height +30 mm. In case of larger gaps bring the construction aperture into compliance with the required dimensions.
2. Check the presence of fixings and tools.
3. Prepare the support blocks (e.g. wood, steel sheet, gypsum). The thickness of the support block must be 10 mm, width 45 mm and maximum length 100 mm.
4. Place the frame without the leaf into the construction aperture. Check levelling of upper profile of the frame.
5. Level the hinge side of the frame and drill the first fixing point through frame. Correct sequence of the fixing points is shown in the figure 2. Make sure that the gaps between the frame and wall are equal when tightening the screws. Place support blocks in the gap against screw, to support every fixing point, then tighten the screws. Check vertical position of the frame side surface. If necessary, loosen the screw and correct position of the frame.

Do the same with fixing spots number 2 and 3. Check vertical position of the frame side surface.

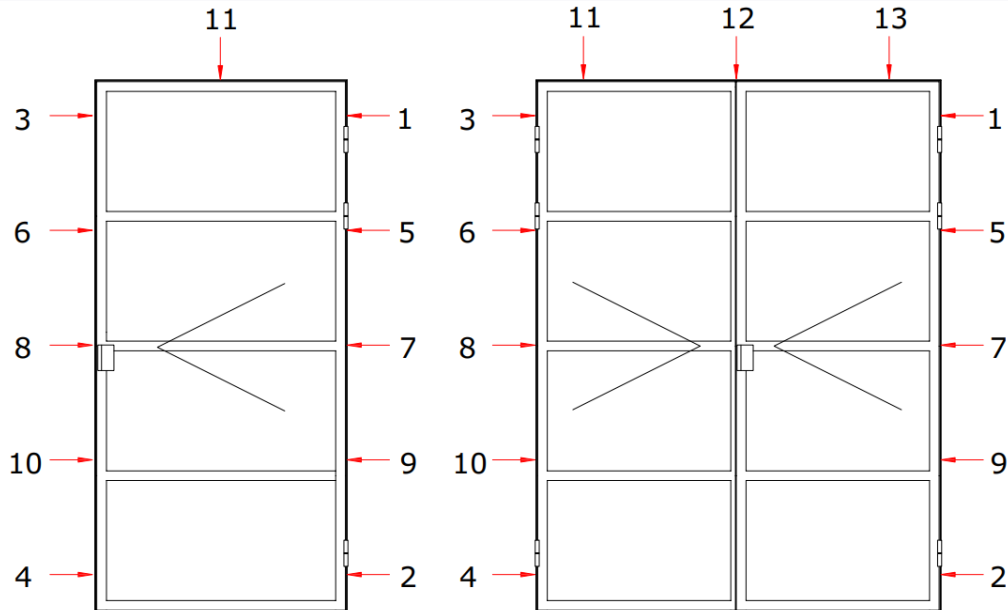

Figure 2 Sequence of fixing points for doors

6. Lift the door leaf on to the hinges and check the parallelity and gap sizes between leaf and frame. Check if the magnet at the top of the frame is working properly with opening and closing the door. If necessary, adjust the screws and width of the support blocks.
7. Fix the frame with remaining fixing points (Figure 2). Support blocks must be added next to every fixing point. Tighten the screws.
8. Check again the parallelity and gap sizes between leaf and frame. If necessary, adjust the screws and width of the support blocks.
9. Close the fixing apertures of the frame with plastic caps.
10. Clean the dust and dirt from the glazing opening.
11. Glass installation is described in the section 2.4.
12. Seal the gaps between wall and frame. For sealing material use fixing foam or stone wool.
13. Sealed gaps must be covered with steel sheets, plaster mixture or construction boards.
14. During installation, make sure that the weatherstripping gasket is installed in the right direction (Figure 3).

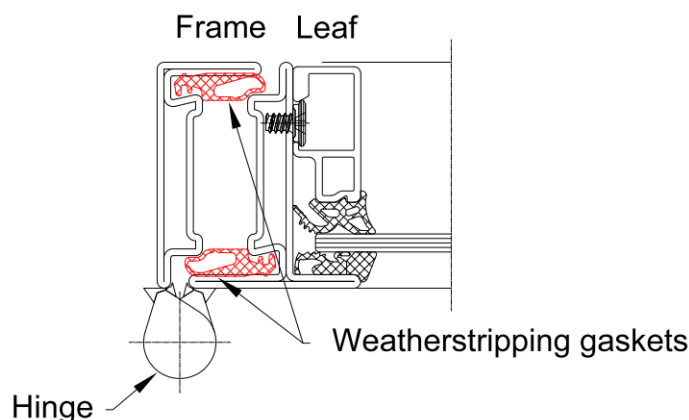

Figure 3 Installation of weatherstripping gaskets



2.3 Order of installation for window/wall

1. Check the preparation of construction aperture. The greatest allowed width of construction aperture from frame is +60 mm and height +30 mm. In case of larger gaps bring the construction aperture into compliance with the required dimensions.
2. Check the presence of fixings and tools.
3. Prepare the support blocks (e.g. wood, steel sheet, gypsum). The thickness of the support block must be 10 mm, width 45 mm and maximum length 100 mm.
4. Place the frame without the glass into the construction aperture. Check levelling of horizontal and vertical profiles of the frame.
5. Level the right side of the frame and drill the first fixing point through frame. Correct sequence of the fixing points is shown in the figure 4.
Make sure that the gaps between the frame and wall are equal when tightening the screws. Place support blocks in the gap against screw, to support every fixing point, then tighten the screws. Check vertical position of the frame side surface. If necessary, loosen the screw and correct position of the frame.

Do the same with fixing spots number 2 and 3. Check vertical position of the frame side surface.

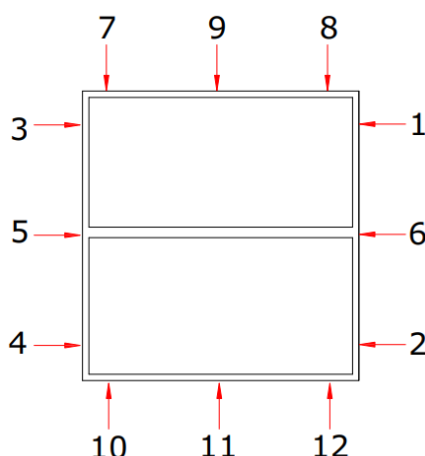

Figure 4 Sequence of the fixing points for fixed glazing

6. Fix the frame with remaining fixing points (Figure 4). Support blocks must be added next to every fixing point. Tighten the screws.
7. Close the fixing apertures of the frame with plastic caps.
8. Clean the dust and dirt from the glazing opening.
9. Glass installation is described in the section 2.4.
10. Seal the gaps between wall and frame. For sealing material use fixing foam or stone wool.
11. Sealed gaps must be covered with steel sheets, plaster mixture or construction boards.

2.4 Glazing

Doors are glazed at AS Saku Metall Uksetehas, windows and walls are glazed on the construction site. Rubber seals are used for glazing. Glazing bead screws are already installed at the factory.

Glazing installation sequence:

1. Clean the dust and dirt from the glazing opening.
2. Place glass supports on to the frame. Height of the glass supports must be 5 mm and thickness must be equal to the glass thickness (Figure 5).

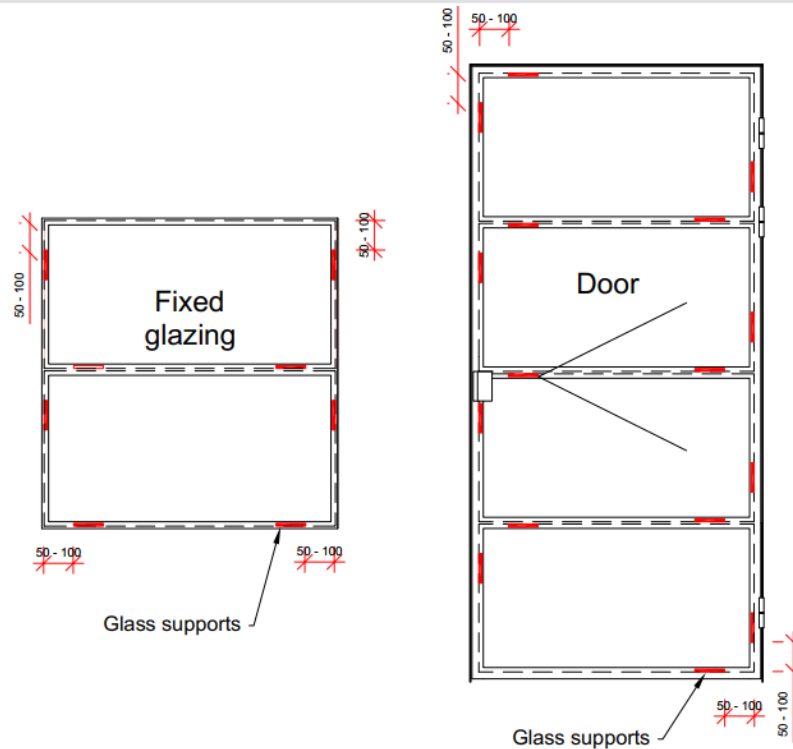

Figure 5 Glass support locations

3. Glue the outer seal onto the frame (if the seals have different thicknesses, then the thinner one must be placed on to the frame). Cut the seal for the corners. First install the seal to the frame corners and then the middle parts. The seal end must be finished at the top of the frame and glued together with contact glue (Figure 6).

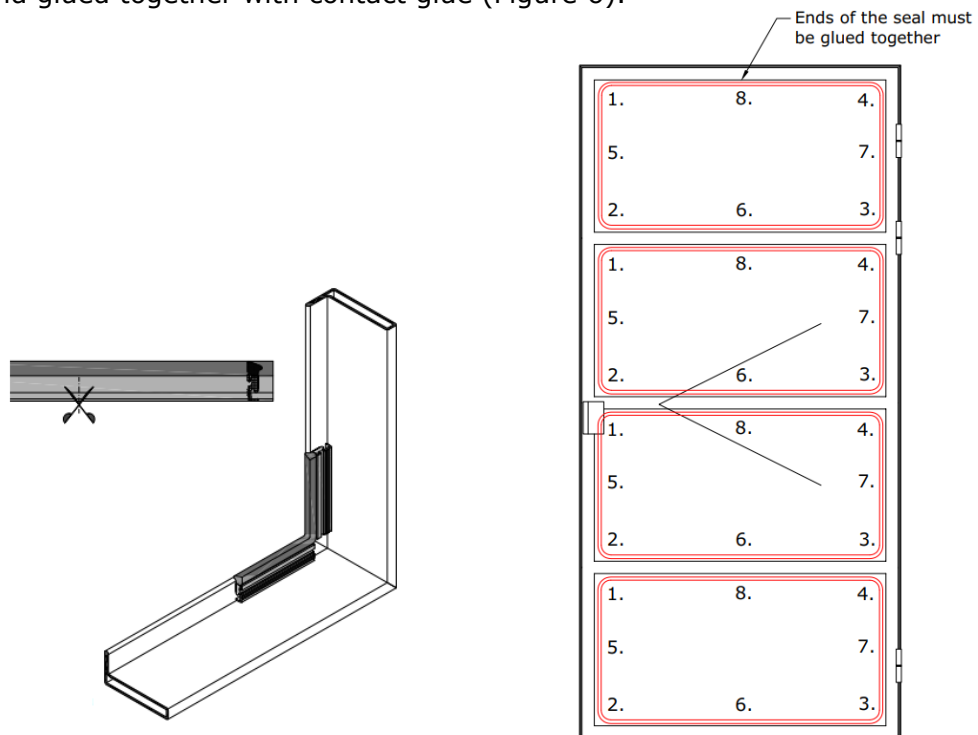

Figure 6 Outer glazing seal installation



4. Lift the glass on to the glass supports, then check that the gaps between the frame and glass is equal at both sides. Maximum allowed gaps on the sides are 5 mm and at the top 6 mm.
5. Install the glazing beads using rubber or plastic hammer. First install the top glazing bead, then the bottom and after that, the sides.
6. After that, rubber seals need to be pressed between glazing beads and glass, that can be done with sealing roll.

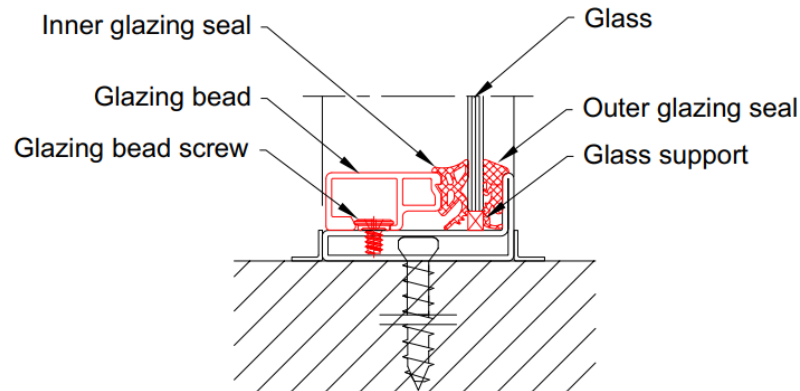

Figure 7 Glass installation