









## Installation manual for external profile product Forster Presto



### Attention! General warnings!

A Series of precautions must be taken to install this product. For safety reasons pay attention to following warnings and instructions! In case of doubt contact the supplier. This manual is meant for experienced installer.

-  Read this manual carefully before installation.
-  Protective gloves are recommended.
-  Parts of the product are heavy.
-  All that is necessary to install this product is included in the package except insulation material between the wall and the frame and support blocks. Adding other elements may affect safety and warranty.
-  Make sure that there is enough light in the installation area. Remove items not necessary and dirt. Unauthorized persons (especially children!) may get hurt if present.
-  Make sure that the wall is strong enough for installation. In case of doubt contact the constructor.
-  If the installation is not in accordance with the instructions and if locks and materials not specified by the manufacturer are used for the door set, the door will lose its performance properties. In this case, the door does not meet its certification and declared properties, and the marking referring to the certificate must be removed from the product by the responsible of the works.

In case of questions contact AS Saku Metall Uksetehas.



**TABLE OF CONTENT**

1 PRODUCT TYPES ..... 2

2 INSTALLATION ..... 2

2.1 Fixtures ..... 2

2.2 Order of installation for door..... 4

2.3 Order of installation for window/wall ..... 6

2.4 Glazing ..... 7

2.5 Connecting profiles by using guides ..... 10

2.6 Glazing seals ..... 11

**1 PRODUCT TYPES**

This installation manual covers only following steel profile products:

1. External steel profile Forster Presto products.

**2 INSTALLATION**

**2.1 Fixtures**

Typical fastener variants according to the wall types are shown in Table 1. When fixing into concrete, concrete masonry, brick, lightweight concrete, or wood, select the length of the screw so that the screw thread reaches at least 50 mm into the wall.

When installing the product between steel construction of light walls made of gypsum or stone wool, the frame may be also fixed with self-tapping screws, with a minimum diameter of 6 mm. The length of the screws must be selected so that its thread passes through the steel profile by at least 10 mm. For sealing material between construction aperture and profile frame use fixing foam or stone wool. Typical fastening methods are shown in figure 1.

**Table 1** Typical fasteners variants according to wall types

Wall type	Fastener variants
<b>Concrete, concrete masonry or brick</b>	Steel sleeve M18 + concrete screw $\varnothing$ 7.5x92 (e.g. Essve 105287)
	Concrete screw $\varnothing$ 10,5x110 (e.g. THDEX 10110)
	Concrete screw $\varnothing$ 7.5x92 (e.g. Essve 105287)
<b>Lightweight concrete</b>	Screw $\varnothing$ 8x100 (e.g. Würth W-1192-8-100) + plastic wall plug
	Concrete screw $\varnothing$ 10,5x110 (näiteks THDEX 10110)
	Steel sleeve M18 + light concrete screw $\varnothing$ 8x120 (e.g. Essve 105232)
	Light concrete screw $\varnothing$ 8x120 (e.g. Essve 105232)
<b>Steel</b>	Screw $\varnothing$ 8x100 (e.g. Würth W-1192-8-100) + plastic wall plug
	Steel sleeve M18 + self-tapping screw $\varnothing$ 7x45 (e.g. Essve 105379)
	Self-tapping screw $\varnothing$ 7x45 TX30 (e.g. Essve 105379)
<b>Wood</b>	Self-tapping screw $\varnothing$ 6.3x50 -120 hexagon (e.g. Würth W-0214-63-50)
	Steel sleeve M18 + wood screw $\varnothing$ 6x65 (e.g. Essve 105294)
	Wood screw $\varnothing$ 6x65 TX30 (e.g. Essve 105294)



1	Fixing foam
2	Cover steel sheet 0,7 mm
3	Screw
4	Fixing plate steel sheet $\geq 2$ mm
5	Screw + wall plug
6	Wood screw
7	Self-tapping screw
8	Steel sleeve M18 with plate

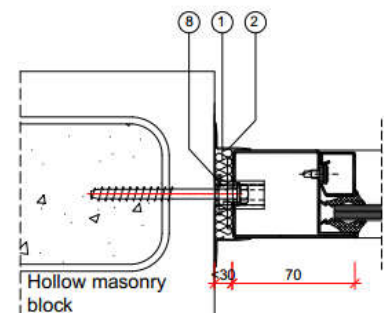
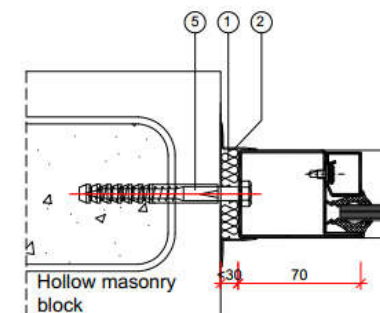
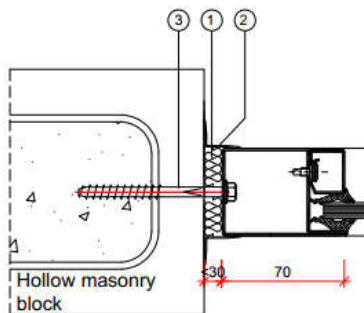
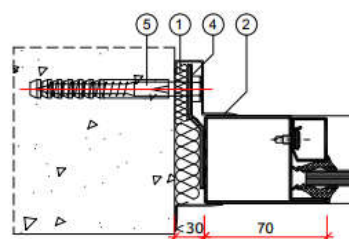
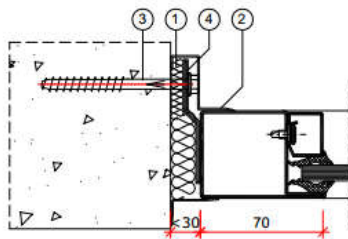
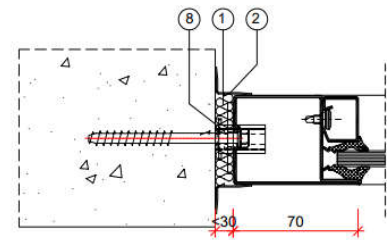
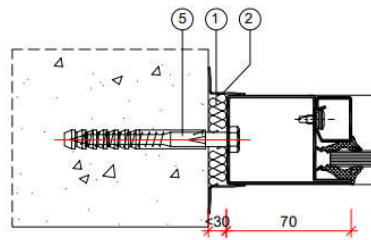
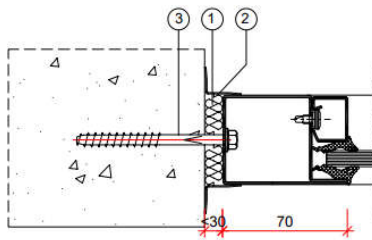
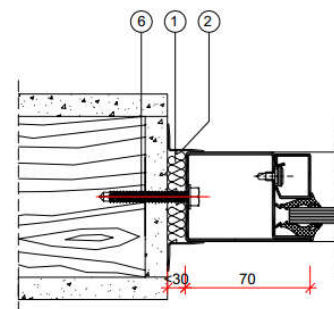
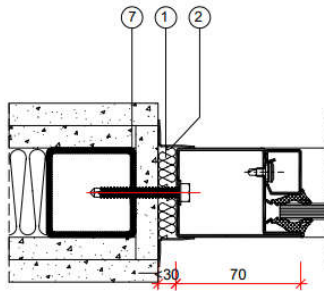

The cavities at the edges must be filled with concrete!

The cavities at the edges must be filled with concrete!

The cavities at the edges must be filled with concrete!

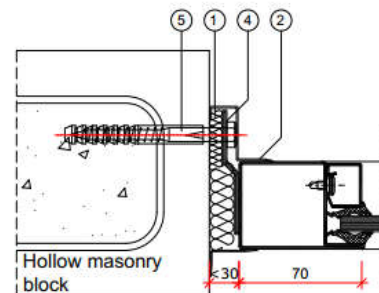
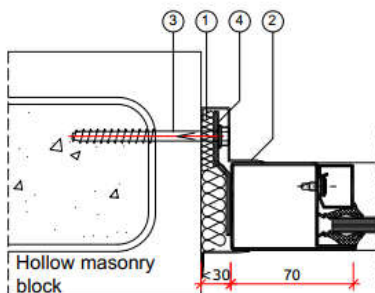

The cavities at the edges must be filled with concrete!

The cavities at the edges must be filled with concrete!

**Figure 1** Typical fastening methods



## 2.2 Order of installation for door

1. Check the preparation of construction aperture. The greatest allowed width of construction aperture from frame is +60 mm and height +30 mm. In case of larger gaps bring the construction aperture into compliance with the required dimensions.
2. Check the presence of fixings and tools.
3. Prepare the support blocks (e.g. wood, steel sheet, gypsum). The thickness of the support block must be 10 mm, width 45 mm and maximum length 100 mm.
4. If necessary, two rows of P-seals can be glued under the threshold for additional sealing (Figure 2).

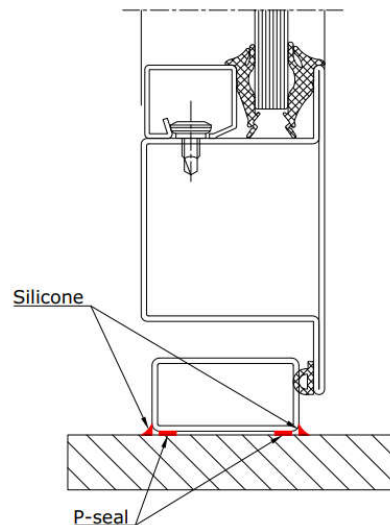

**Figure 2** Adding silicone and P-seals

5. Place the frame without the leaf into the construction aperture. Ensure that the frame is supported at the bottom to prevent deformation of the frame during operation. Check levelling of upper profile of the frame. Support the threshold as close as possible to the fixing points, to avoid its excessive bending upon stepping.
6. Level the hinge side of the frame and drill the first fixing point through frame. Correct sequence of the fixing points is shown in the figure 3.

### 6.1. Frame without steel sleeves.

Make sure that the gaps between the frame and wall are equal when tightening the screws. Place support blocks in the gap against screw, to support every fixing point, then tighten the screws. Check vertical position of the frame side surface. If necessary, loosen the screw and correct position of the frame.

### 6.2. Frame with steel sleeves.

Tighten the sleeves against the wall. Frames with sleeves do not require support blocks between the frame and the wall. If the sleeve does not extend to the wall, use additional plates. Use proper fixings for ESSVE sleeves (section 1 Fixtures). Tighten the screws.

Do the same with fixing spots number 2 and 3. Check vertical position of the frame side surface.

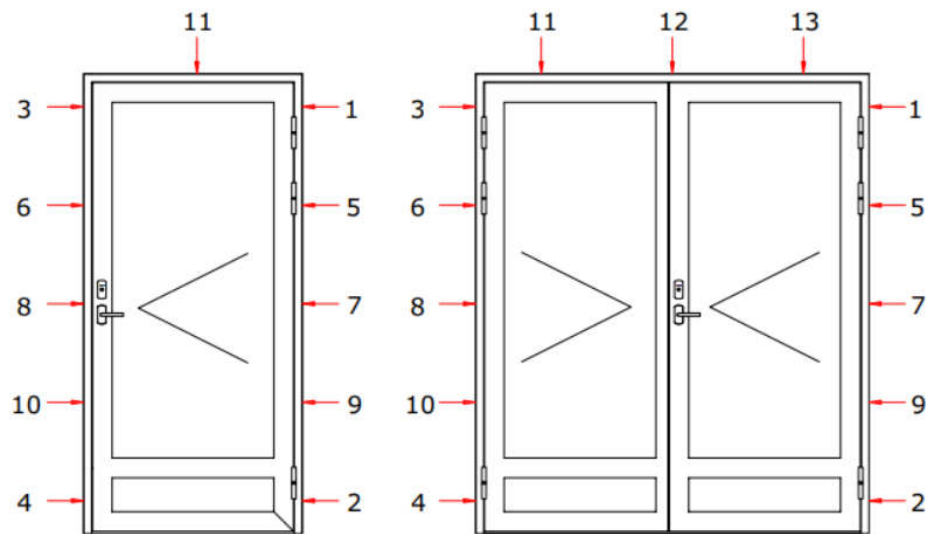

**Figure 3** Sequence of fixing points for doors

7. Lift the door leaf on to the hinges and check the parallelity between leaf and frame. If necessary, adjust the screws (or steel sleeves) and width of the support blocks.
8. Fix the frame with remaining fixing points (Figure 3). Support blocks must be added next to every fixing point. Tighten the screws.
9. Close the fixing apertures of the frame with plastic caps.
10. Clean the dust and dirt from the glazing opening.
11. Glass installation is described in the section 2.4.
12. Seal the gaps between wall and frame. For sealing material use fixing foam.
13. Sealed gaps must be covered with steel sheets, plaster mixture or construction boards.
14. Use silicone Soudaflex 40FC, SOUDAL Silirub 2/S or Penosil General Silicone for the threshold and/or wall section (Figure 2).
15. During installation, make sure that the weatherstripping gasket is installed in the right direction (Figure 4).

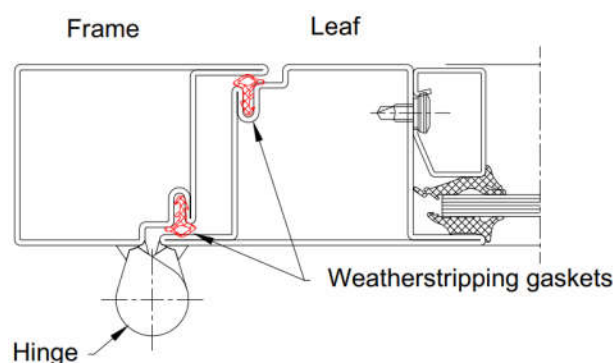

**Figure 4** Installation of weatherstripping gaskets

16. Install locks (and other hardware) according to the installation manual. Fix handles to the lock and check closure and operation of lock cylinder (and latch bolt) with opening and closing of door. Check opening of lock with keys.
17. Check with induction tester that the product is not under voltage. Otherwise switch off the power and ground the product. Electrical operations can be performed only by a qualified electrician. AS Saku Metall Uksetehas does not perform electrical operations.



### 2.3 Order of installation for window/wall

1. Check the preparation of construction aperture. The greatest allowed width of construction aperture from frame is +60 mm and height +30 mm. In case of larger gaps bring the construction aperture into compliance with the required dimensions.
2. Check the presence of fixings and tools.
3. Prepare the support blocks (e.g. wood, steel sheet, gypsum). The thickness of the support block must be 10 mm, width 45 mm and maximum length 100 mm.
4. If necessary, two rows of P-seals can be glued under the frame for additional sealing (Figure 5).

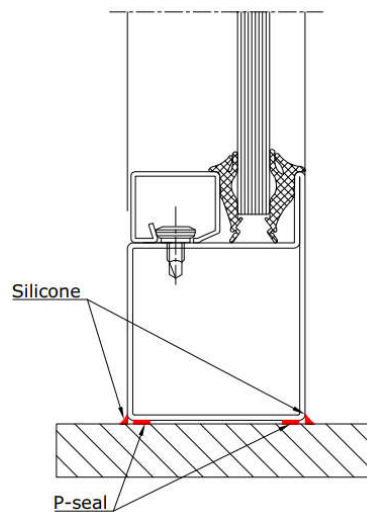

**Figure 5** Adding silicone and P-seals

5. Place the frame without the glass into the construction aperture. Check levelling of horizontal and vertical profiles of the frame.
6. Level the right side of the frame and drill the first fixing point through frame. Correct sequence of the fixing points is shown in the figure 6.
  - 6.1. Frame without steel sleeves.

Make sure that the gaps between the frame and wall are equal when tightening the screws. Place support blocks in the gap against screw, to support every fixing point, then tighten the screws. Check vertical position of the frame side surface. If necessary, loosen the screw and correct position of the frame.
  - 6.2. Frame with steel sleeves.

Tighten the sleeves against the wall. Frames with sleeves do not require support blocks between the frame and the wall. If the sleeve does not extend to the wall, use additional plates. Use proper fixings for ESSVE sleeves (section 1 Fixtures). Tighten the screws.

Do the same with fixing spots number 2 and 3. Check vertical position of the frame side surface.

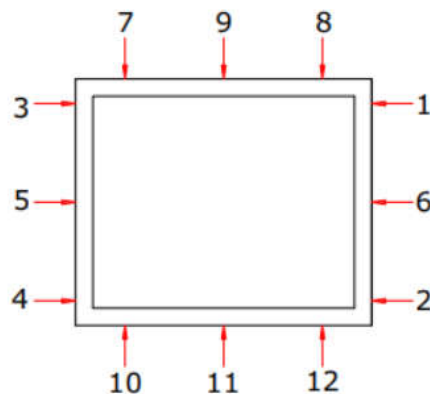

**Figure 6** Sequence of the fixing points for fixed glazing

7. Fix the frame with remaining fixing points (Figure 6). Support blocks must be added next to every fixing point. Tighten the screws.
8. Close the fixing apertures of the frame with plastic caps.
9. Clean the dust and dirt from the glazing opening.
10. Glass installation is described in the section 2.4.
11. Seal the gaps between wall and frame. For sealing material use fixing foam.
12. Sealed gaps must be covered with steel sheets, plaster mixture or construction boards.
13. Use silicone Soudaflex 40FC, SOUDAL Silirub 2/S or Penosil General Silicone for the threshold and/or wall section (Figure 5).

## 2.4 Glazing

Doors are glazed at AS Saku Metall Uksetehas, windows and walls are glazed on the construction site. Rubber seals are usually used for exterior products, but it is also possible to use square shaped seals, but then the seals must be covered with silicone. Glazing bead screws are already installed at the factory.

Glass may be replaced by panel. Panels consist of polystyrene foam board (EPS) surrounded by 1,5 mm steel sheets. In addition, it is possible to add riveted or welded on steel sheets on to the frame (Figure 7).

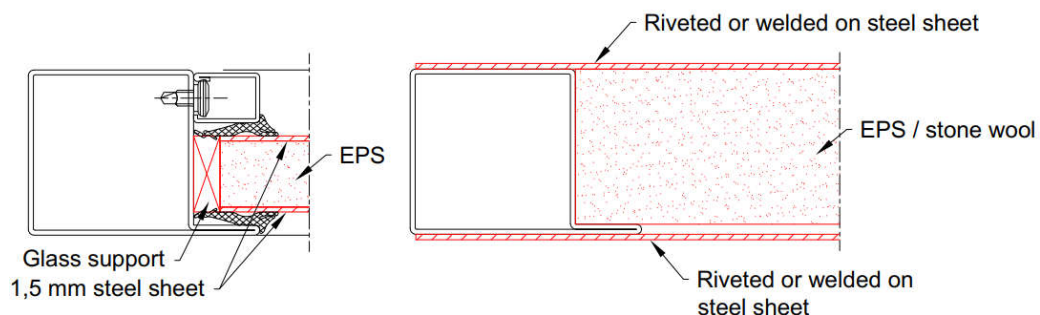

**Figure 7** Panel variants

Glazing installation sequence:

1. Clean the dust and dirt from the glazing opening.
2. Place glass supports on to the frame. Height of the glass supports must be 10 mm and thickness must be equal to the glass thickness (Figure 8).

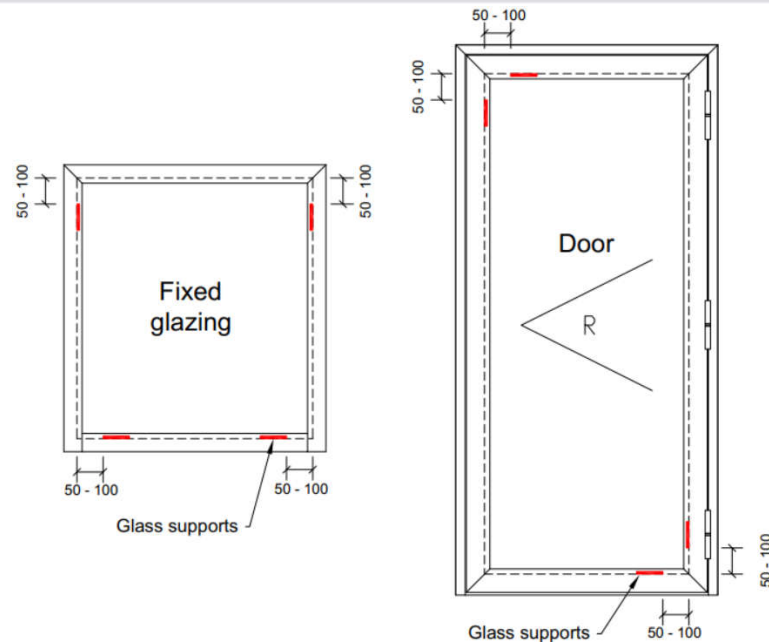

**Figure 8** Glass support locations

3. When using **rubber glazing seals**:

3.1. Glue the outer seal onto the frame (if the seals have different thicknesses, then the thinner one must be placed on to the frame). Cut the seal for the corners. First install the seal to the frame corners and then the middle parts. The seal end must be finished at the top of the frame and glued together with contact glue (Figure 9).

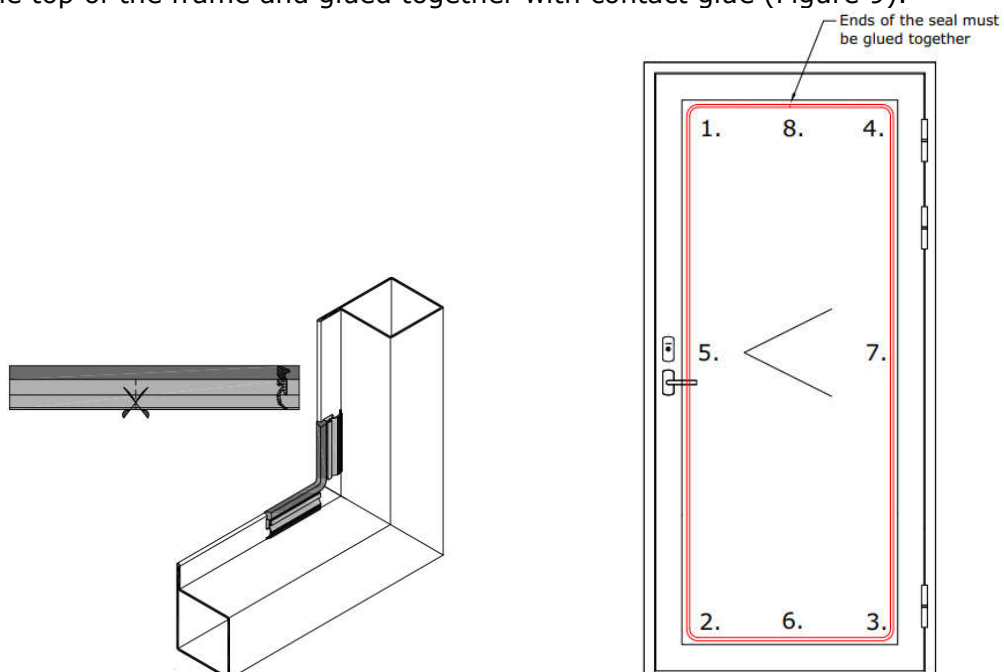

**Figure 9** Outer glazing seal installation

3.2. Glue inner glazing seals onto the glazing beads. Cut the ends of the vertical glass seals at 45 degrees, leaving the seals slightly longer than the glazing beads (Figure 10).



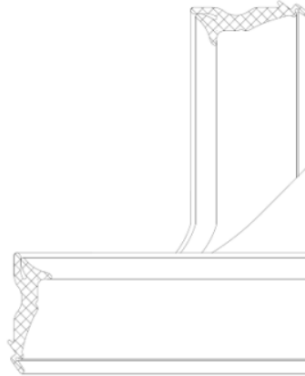

**Figure 10** Inner glazing seal installation

- 3.3. Lift the glass on to the glass supports, then check that the gaps between the frame and glass is equal at both sides. Maximum allowed gaps on the sides are 8 mm and at the top 6 mm.
- 3.4. Install the glazing beads using rubber or plastic hammer. First install the top glazing bead, then the bottom and after that, the sides.

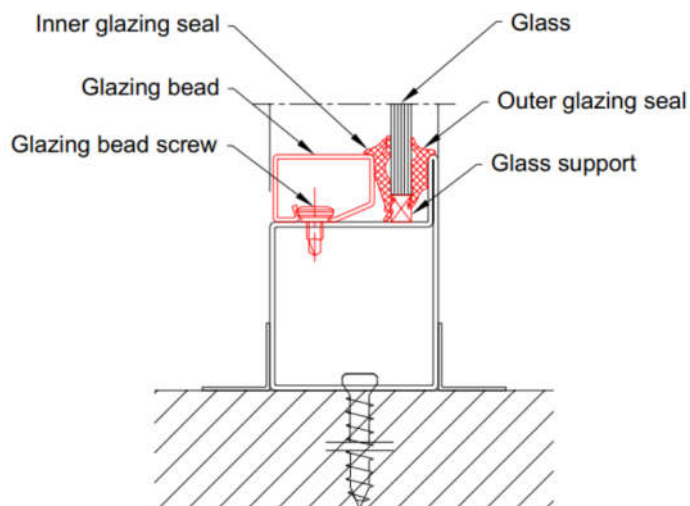

**Figure 11** Glass installation

4. When using **square shaped glazing seals:**

- 4.1. Glue the outer seal onto the frame (if the seals have different thicknesses, then the thinner one must be placed on to the frame) (Figure 12).

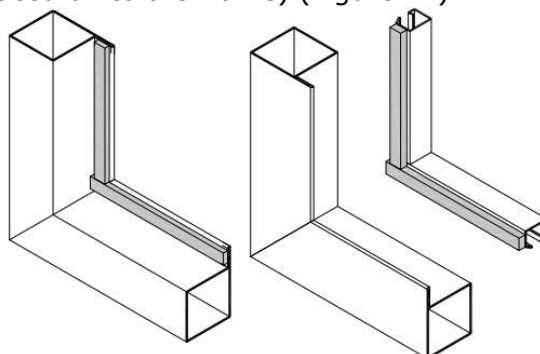

**Figure 12** Square shaped seal installation



- 4.2. Glue the gaskets so that the edge of the gasket remains approximately 5 mm below the edge of the profile (Figure 12).
- 4.3. Lift the glass on to the glass supports, then check that the gaps between the frame and glass is equal at both sides. Maximum allowed gaps on the sides are 8 mm and at the top 6 mm.
- 4.4. Install the glazing beads using rubber or plastic hammer. First install the top glazing bead, then the bottom and after that, the sides.
- 4.5. Cover seals with silicone (Figure 13).

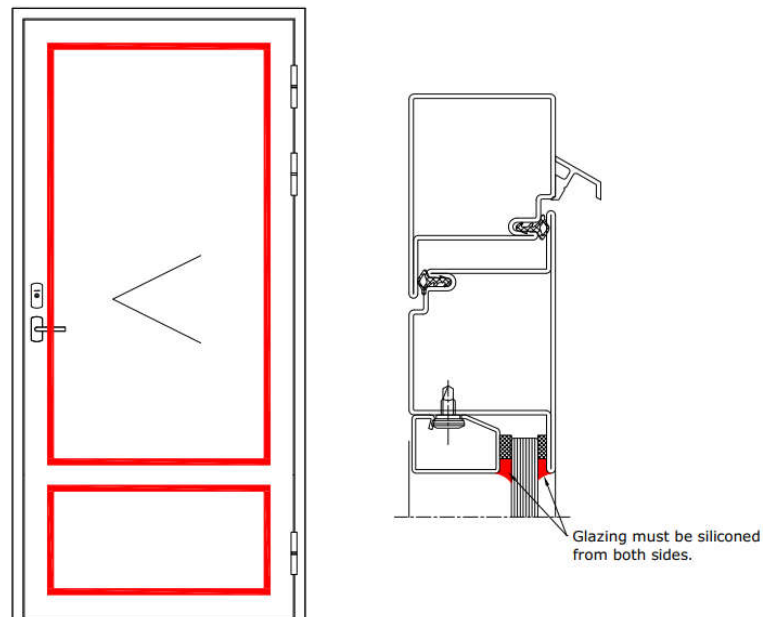
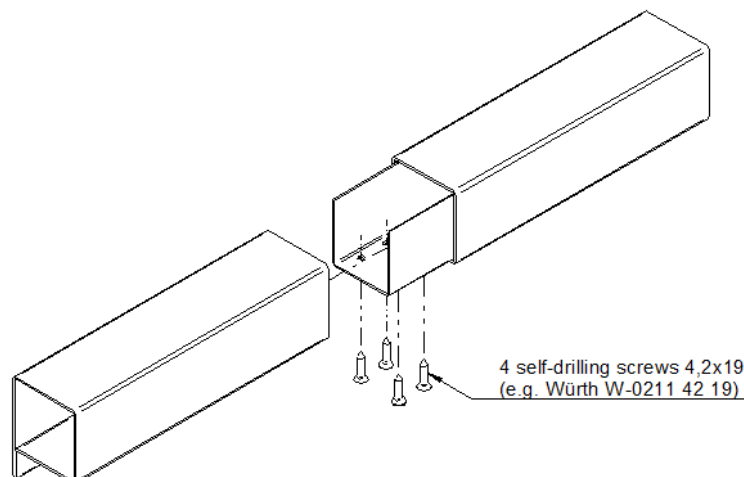

**Figure 13** Using silicone for square shaped gaskets.

5. Alternative to glazing beads, it is possible to use L-profiles (wall thickness 2 or 3 mm) or square tubes. These are attached to the frame with self-tapping screws.

## 2.5 Connecting profiles by using guides

Products with large dimensions are produced by using connecting profiles. Different parts of the frame are assembled at the construction site using self-tapping screws (Figure 14).



**Figure 14** Assembling with connecting profiles



## 2.6 Glazing seals



**EPDM glazing seal**

4302 - 3mm

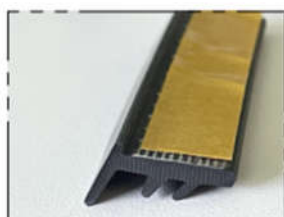

**EPDM glazing seal**

4111 - 4-5mm

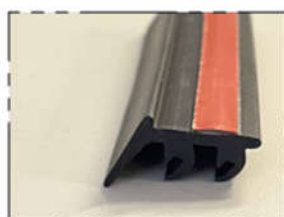

**EPDM glazing seal**

4119 - 5-7mm



**Rectangular glazing seal**

- 2x8mm
- 3x8mm
- 4x8mm
- 5x8mm
- 6x8mm
- 7x8mm

**Figure 15** Forster Presto glazing seals